



**Accident to an aircraft Tecnam P2002-JF,  
national and registration markings LY-BAQ,  
that occurred on 14 August 2017  
in S. Darius and S. Girėnas aerodrome, Kaunas,  
the Republic of Lithuania,**

**FACTUAL REPORT**

Transport  
Accident and  
Incident  
Investigation Division



The safety investigation is conducted in accordance with Annex 13 to the Convention on International Civil Aviation and Regulation (EU) No 996/2010 of the European Parliament and of the Council of 20 October 2010 on the investigation and prevention of accidents and incidents in civil aviation and repealing Directive 94/56/EC.

**The purpose of the safety investigation is to prevent the occurrence of accidents and incidents in the future, rather than establish blame or liability. The safety investigation is conducted independently of any judicial or administrative proceedings, to apportion blame or liability, are not related to them, and have no impact thereupon.**

Each safety investigation shall be concluded with a report in a form appropriate to the type and seriousness of the accident or serious incident. The report shall contain, where appropriate, safety recommendations, which shall in no case create a presumption of blame or liability for an accident or serious incident.

In accordance with the provisions, the safety investigation report cannot be used as evidence in a judicial or administrative process seeking to apportion blame or liability, because this was not established in the course of the safety investigation and it is not compatible with the objective of the safety investigation.

This information is published to inform the aviation industry and the public of the general circumstances of accident or serious incident. Extracts may be published without specific permission providing that the source is duly acknowledged, the material is reproduced accurately and it is not used in a derogatory manner or in a misleading context.

This is a courtesy translation by the Transport Accident and Incident Investigation Division of the Factual Report on the Safety Investigation. As accurate as the translation may be, the original text in Lithuania is the authentic version and the work of reference.

**MINISTRY OF JUSTICE OF THE REPUBLIC OF LITHUANIA**  
**TRANSPORT ACCIDENT AND INCIDENT INVESTIGATION DIVISION**

---

Budgetary agency,  
Gedimino ave. 30,  
LT-01104, Vilnius  
Tel. +370 266 2984  
Fax. +370 262 5940  
e-mail. rastine@tm.lt  
www.tm.lt

Data have been accumulated and stored in the Register of Legal Entities  
Code 188604955

## Summary

Occurrence No.	A-17/08	
Report No.	(8.4.5)1A-69(A-17/08)	
Type of Report	Factual Report	
Published	22 June 2018	
Type of Occurrence	ACCIDENT	
Date	14 August 2017	
Local Time	12:04 hrs	
Location	S. Darius and S. Girėnas aerodrome, Kaunas	
Aircraft Type	Tecnam P2002-JF	
Registration	LY-BAQ	
Serial No.	233	
Year of Manufacture	2013 m.	
Type of Flight	Training	
Nature of Damage	Damage to the nose landing gear	
Persons on Board	Crew – 1	Passengers – None
Injuries	Crew – None	Passengers – N/A
Commander's Licence	Student pilot permit	
Commander's Age	24 years	
Commander's Flying Experience	9 hours 55 min	

## Synopsis

On 14 August 2017 student pilot had to perform her first solo flight. After the aircraft landed on the runway, the nose landing gear strut was broken off. The aircraft with the broken nose landing gear strut slipped on the runway until it stopped. The student pilot had no injuries.

## Notification

The safety investigation authority was informed about the accident of the aircraft Tecnam P2002-JF, registration LY-BAQ, by approved training organization at 12:27 hrs.

Civil Aviation Safety Investigation and Analysis Center of Romania (*Centrul de Investigatii si Analiză pentru Siguranta Aviatiei Civile*) and The Italian Civil Aviation Safety Investigation Authority (*Agenzia Nazionale per la Sicurezza del Volo*) appointed Accredited Representatives.

## **1. FACTUAL INFORMATION**

### **1.1. History of the flight**

On 14 August 2017 the student pilot had to perform her first traffic circuit solo flight – two flights with one touch-and-go within the aerodrome traffic zone.

The student pilot took off from the aerodrome runway No. 27 with the aircraft Tecnam P2002-JF at 11:45 hrs. The student pilot stated, that the first traffic circle did not cause any problems. However, she noted that the control of the aircraft felt different because the aircraft was lighter than usually when flying with a flight instructor. During the second landing the aircraft bounced back from the runway three times, therefore the student pilot terminated the landing immediately and took off to perform another traffic circle. During preparation for the third landing, the control of the aircraft and the descent became complicated. The aircraft touched the ground with its main landing gear, bounced back and hit the runway with the nose landing gear.

According to the senior flight instructor who observed the first solo traffic circuit flight of the student pilot, during the third landing the aircraft was stabilized at a higher altitude. It touched the runway with its main landing gear, bounced back and hit the runway with the nose landing gear.

### **1.2. Damage to aircraft**

As a result of the accident, the strut of the nose landing gear was broken off, the engine mounting frame was deformed, the tips of the propeller blades were cut off and the engine lower cowling was damaged.

### **1.3. Personnel information**

#### **1.3.1. The student pilot**

The student pilot was a 24-year-old Romanian citizen. During the accident she held a student pilot's permit issued by an approved training organization on 10 July 2017 and valid until 25 November 2018.

The student pilot held a Class I medical certificate without restrictions issued by the Aviation Medicine Centre of Vilnius City Clinical Hospital on 18 November 2016 and valid until 18 November 2017.

The student pilot's flying experience with an instructor was 9 hours 55 minutes, of which 7 hours 25 minutes were completed during the last 30 days.

### 1.3.2. Assessment of the student pilot's skills

Commission Regulation (EU) No 1178/2011 of 3 November 2011 laying down technical requirements and administrative procedures related to civil aviation aircrew pursuant to Regulation (EC) No 216/2008 of the European Parliament and of the Council indicates:

*FCL.020 Student pilot*

*A student pilot shall not fly solo unless authorised to do so and supervised by a flight instructor.*

It was confirmed by the approved training organization that an additional assessment of a student pilot's skills is performed before every student pilot's first flight.

The student pilot was assessed by the senior flight instructor at the same day, her progress was evaluated as average and she was allowed to perform her first traffic circuit solo flight. The assessment sheet of the student pilot indicated the following:

*<...> and maintain higher altitude during flare.*

### 1.3.3. The flight instructor

The flight instructor was a 23-years-old citizen of Kingdom of Spain. He had a Commercial Pilot Licence CPL(A) issued 25 January 2016 by the Spanish Aviation Safety and Security Agency (*Agencia Estatal de Seguridad Aérea*). It listed the multi engine piston class rating MEP(land), the single engine piston class rating SEP(land), instrument rating IR(A) and flight instructor FI(A).

The flight instructor held a Class I medical certificate issued on 6 October 2016 and valid until 9 October 2017.

The flight instructor flying experience was 450 hours and 29 min.

### 1.3.4. The senior flight instructor

The senior flight instructor was a 40-year-old citizen of the Republic of Lithuania, holding a commercial pilot's licence CPL(A) issued by the Civil Aviation Administration of the Republic of Lithuania on 11 July 2008. The licence included the valid qualifications for multi-engine piston class rating MEP(land), single-engine piston class rating SEP(land), An-2 aircraft type, single and multi-engine piston class rating SEP/MEP(land)/ instrument rating IR(A) and flight instructor FI(A) for single-engine piston class rating SEP (land).

The senior flight instructor held a Class I medical certificate without restrictions issued on 13 June 2017 and valid until 17 June 2018.

The senior flight instructor flying experience was 3400 hours, of which 950 hours were instructor flights.

## 1.4. Aircraft information

### 1.4.1. Information of the aircraft

General information of the aircraft Tecnam P2002-JF are presents in Table 1.

Table 1. General information of the aircraft Tecnam P2002-JF

Certificate of Registration issue date	15 December 2015
Certificate of Airworthiness issue date	27 May 2013
Certificate of Airworthiness Review issue date	7 April 2017
Airworthiness Review Certificate valid	17 April 2018
Total flight hours	1795 hrs
Flight hours after the last periodic inspection	45 hrs 20 min

### 1.4.2. Mass and centre of gravity of the aircraft

The mass and the position of the mass balance of the aircraft during the accident corresponded to the requirements of the Aircraft Flight Manual No. 2002/028 (3<sup>rd</sup> Edition, Rev. 7) issued on 19 May 2017.

### 1.4.3. Description of the nose landing gear

The Aircraft Maintenance Manual No. 2002/30 (2<sup>nd</sup> Edition, Rev. 1) issued on 14 March 2016 indicates:

#### *32-30 Nose landing gear*

##### *Description and operation*

*The nose gear (fig. 20) is attached to the engine mount with two hinges (1) and is equipped with a 4.00-6 type tire.*

*Steering motion is transmitted from the pedals through two steering tubes that are attached to the nose gear strut by means of two brackets (2) welded to the strut.*

*Gear fork is made up of light alloy plates (4) & (5) and a spacer (6); it hinges on the strut leg and is braced by a rubber-disc shock absorber (3).*

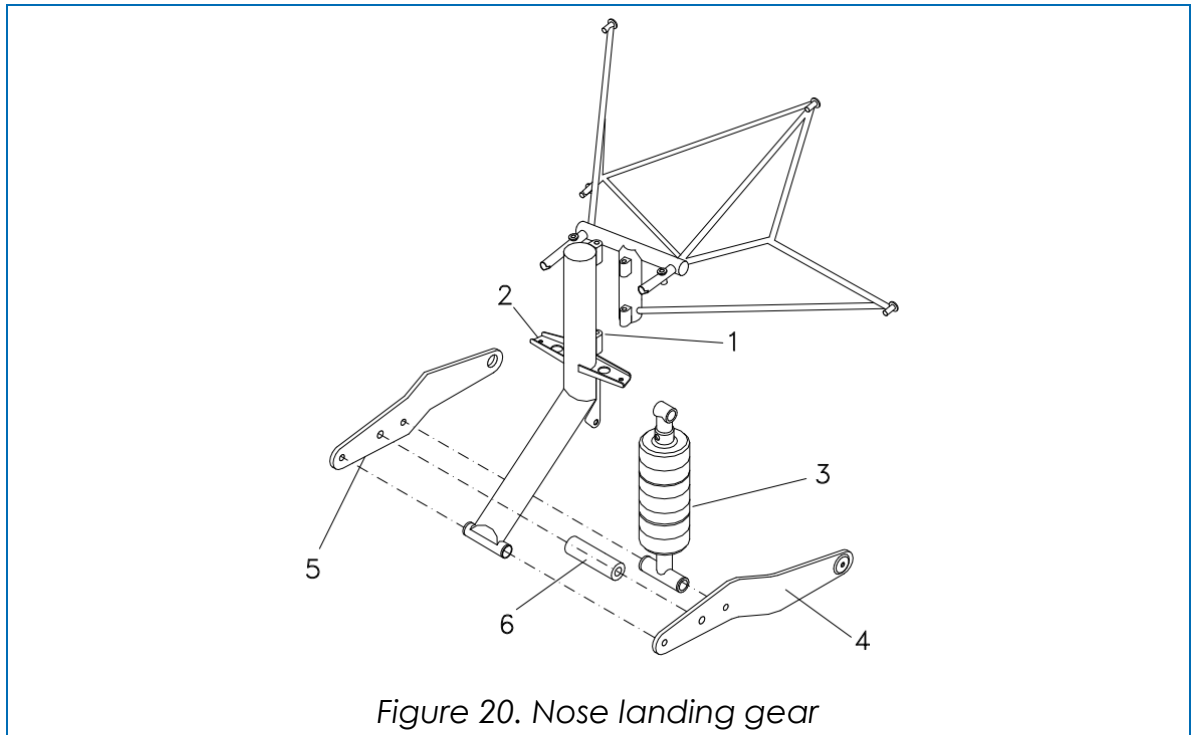

#### 1.4.4. Metallurgical examination of nose landing gear strut

The metallurgical examination of the nose landing gear strut was carried out by the Forensic Science Centre under the Ministry of Justice of the Republic of Lithuania. The inspection report No. 11-1878(17) of the Forensic Science Centre issued 27 November 2017 indicates:

##### CONCLUSION

*The nose landing gear of the aircraft Tecnam P2002-JF, registration LY-BAQ, received for inspection became separated after being exposed to bending loads that exceeded the tensile strength of the metal of its strut.*

*The separation of the nose landing gear strut of the aircraft Tecnam P2002-JF, registration LY-BAQ, was a onetime instantaneous event.*

#### 1.5. Meteorological information

The Kaunas meteorological station of the Lithuanian Hydrometeorology Service under the Ministry of Environment recorded the weather conditions that are presented in Table 2. The station is located in 3 km to the west from the accident site.

Table 2. Meteorological information

Local time	Air temperature, °C	Wind direction	Average wind speed, m/s	Maximum wind speed, m/s	Cloud cover, okta	Pressure at the sea level, hPA
12:00	19,3	north-west	4	7	5	1013,6

## 1.6. Communications

The radio communication between the aircraft and the aerodrome was recorded. The record was received during the safety investigation.

## 1.7. Video record

The first traffic circuit solo flight of the student pilot was filmed using a mobile phone. The video was received during the safety investigation and it showed all three landings of the student pilot.

The video showed that during the third landing, the aircraft touched the runway and bounced back. Then it touched the runway one more time and after a short bounce, it hit the runway. Then the aircraft started to slide.

## 1.8. Aerodrome information

The S. Darius and S. Girėnas aerodrome flight instructions approved by Director of aerodrome and in line with Director of the Civil Aviation Administration of 28 July 2016 indicates:

*Chapter 2. Aerodrome data*

*2.3. Geographical coordinates of the Aerodrome Control Point (ACP) in the WGS-84 system:*

*2.3.1. 54° 52' 47" north latitude;*

*2.3.2. 023° 52' 51" east longitude.*

*2.4. ACP altitude above the average sea level  $H_{aer} = +245$  feet's (+75 m).*

*<...>*

*Chapter 5. Flight operations*

*5.3. All flights in aerodrome traffic zone must be performed with radio equipment maintained at 135,500 MHz frequency.*

*<...>*

*Annex 1. Scheme of aerodrome*

*Runway No. 09, magnetic course 087°.*

*Runway No. 27, magnetic course 267°.*

*Runway dimensions 1158 m x 50 m. The coating - asphalt.*

### 1.9. Wreckage and impact information

Fig. 1. shows the scheme of the accident. Dimensions are given in meters.

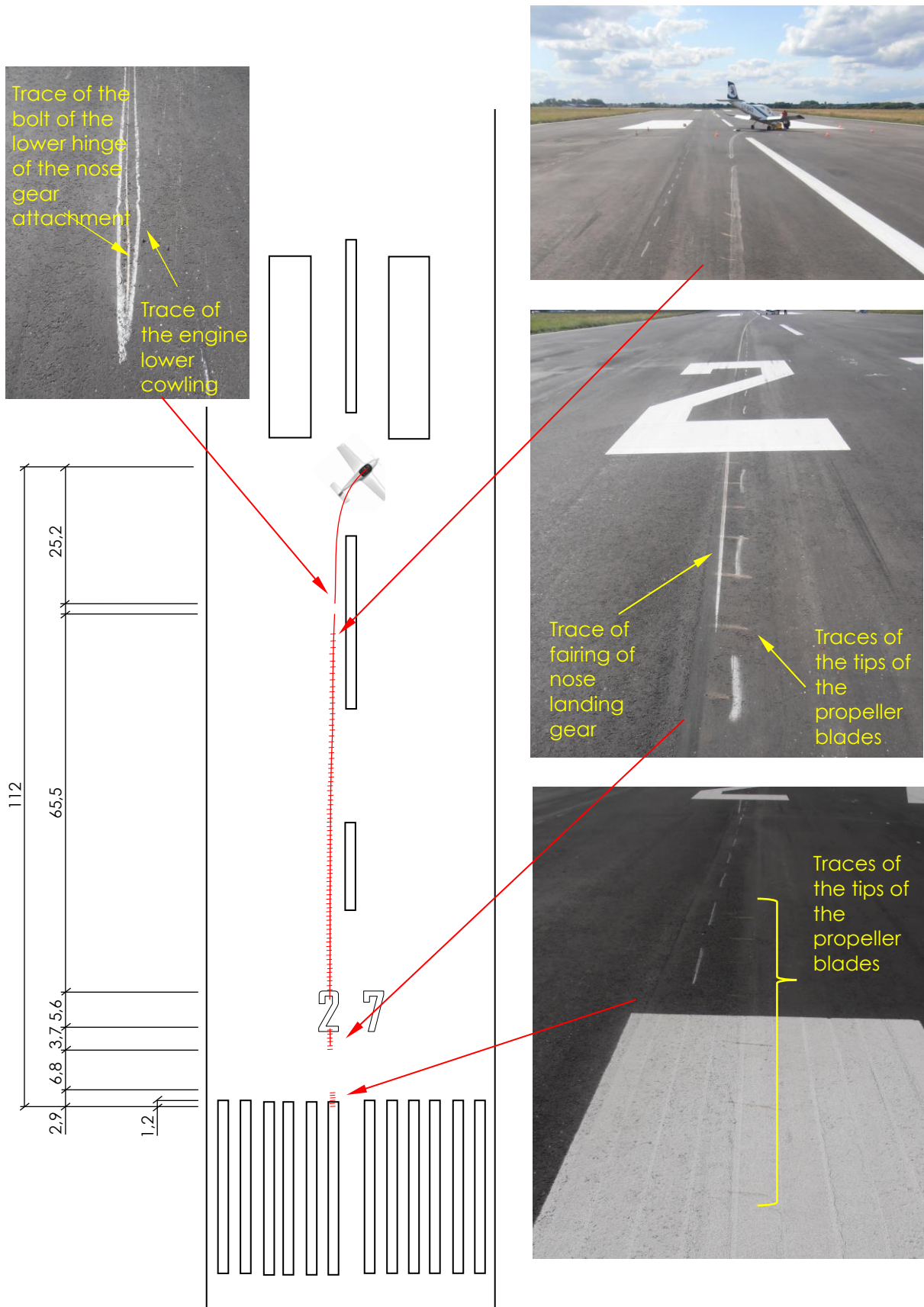

Fig. 1. The scheme of the accident site

It was observed at the site of the accident that the initial traces of the blades of the rotating propeller were left on the marking strip of the runway threshold. The length of the traces were 2.9 meters. The traces of the blades of the rotating propeller were again detected after 6.8 meters. Also, this was the point where the trace left by the left side of the front fairing of the broken nose landing gear began and continued for 75 meters. After the trace became discontinued, the traces of the bolt of the lower hinge of the nose gear and the lower cover of the engine were detected after 0.5 meter, which continued for about 25 meters. The broken nose gear was found on the left side of the trace (Fig. 2).

The aircraft stopped on the runway after sliding for about 102 meters and rotating at an angle of about 50° to the right, comparing to the initial landing direction (Fig. 2).

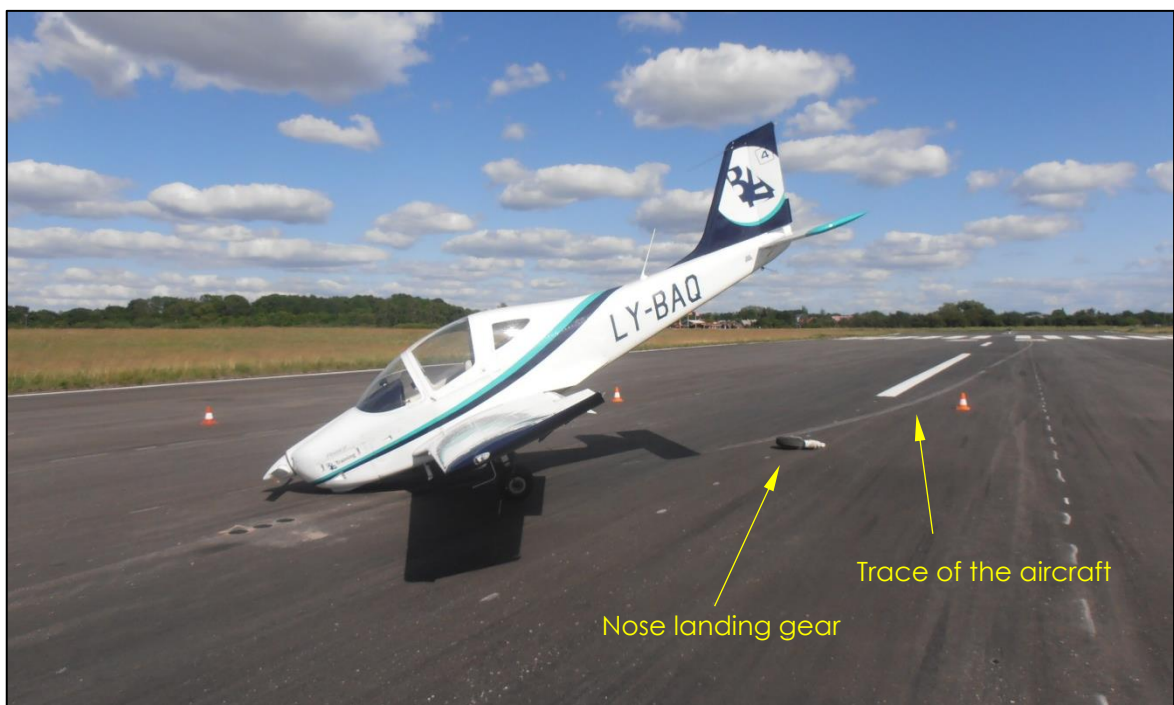

Fig. 2. The aircraft Tecnam P2002-JF at the site of the accident

## 2. COMMENTS

During the first traffic circuit solo flight of the student pilot the aircraft was stabilized at a higher altitude. While parachuting from the higher altitude, the aircraft gained greater vertical speed and touched the runway with a respective impact to the landing gear. As a result of loads that originated during the impact and exceeded the tensile strength of the metal of the nose landing gear strut, the landing gear of the aircraft was broken off.